



# MIC-SC-MA 304817

Hilti North America  
Installation Technical Manual  
Technical Data  
MI System

Version 1.2      08.2017



## Terms of common cooperation / Legal disclaimer

The product technical data published in these Technical Data Sheets are only valid for the mentioned codes or technical data generation methods and the defined application conditions (e.g. ambient temperature load capacity not valid in case of fire, data not valid in support structures when mixed with third party products, values only apply to static loading conditions). Technical data applies to the component only -- suitability and capacity of all other components must be checked separately by the responsible engineer (e.g., other assembly components, attachments, base materials, and building structures).

Suitability of structures combining different products for specific applications needs to be verified by conducting a system design and calculation, using for example Hilti PROFIS software. In addition, it is crucial to fully respect the Instructions for Use and to assure clean, unaltered and undamaged state of all products at any time in order to achieve optimum performance (e.g. avoid misuse, modification, overload, corrosion).

As products but also technical data generation methodologies evolve over time, technical data might change at any time without prior notice. We recommend to use the latest technical data sheets published by Hilti.

In any case the suitability of structures combining different products for specific applications need to be checked and cleared by an expert, particularly with regard to compliance with applicable norms, codes, and project specific requirements, prior to using them for any specific facility. This book only serves as an aid to interpret the capacity of the components listed, without any guarantee as to the absence of errors, the correctness and the relevance of the results or suitability for a specific application. User must take all necessary and reasonable steps to prevent or limit damage. The suitability of structures combining different products for specific applications need to be confirmed with a professional designer and/or structural engineers to ensure compliance with User's specific jurisdiction and project requirements.

## MIC-SC-MA Base Material Connector - Steel

|                  |               |
|------------------|---------------|
| Designation      | Item number   |
| <b>MIC-SC-MA</b> | <b>304817</b> |

### Corrosion protection:

Hot dipped galvanized per DIN EN ISO 1461:

|            |                              |
|------------|------------------------------|
| Connector: | 2.2 mils (55 $\mu\text{m}$ ) |
| Bolt:      | 1.8 mils (45 $\mu\text{m}$ ) |
| Nut:       | 1.8 mils (45 $\mu\text{m}$ ) |

### Weight:

20.72 lb (9400 g) incl. components

### Description:

Hilti Hot-dipped galvanized baseplate connector, typically used for anchoring a MI-90 girder to a steel beam at an angle, usually when it's used as a brace for another girder. Four oblong anchor holes enable fine tuning of baseplate position, and girder is connected using one bolt through a hole, which enables various angles. For use with **M16** hardware.

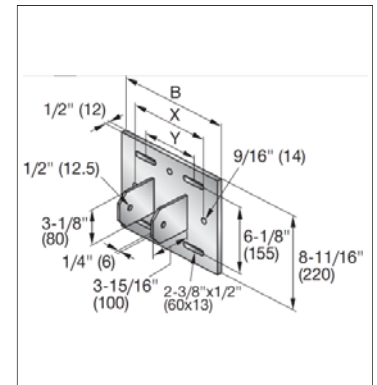

Hardware included per connector

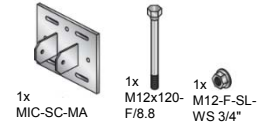

### Material properties:

| Material                                     | Yield strength   | Ultimate strength   | E-modulus   | Shear modulus  |
|--|--|---|---|--|
| Connector                                    |  |   |   |  |
| S235JR - DIN EN10025-2 2005.4                | $f_y = 34.08 \text{ ksi}$ (235 $\frac{N}{\text{mm}^2}$ ) | $f_u = 52.21 \text{ ksi}$ (360 $\frac{N}{\text{mm}^2}$ )  | $E = 29000 \text{ ksi}$ (200000 $\frac{N}{\text{mm}^2}$ ) | $G = 11000 \text{ ksi}$ (75845 $\frac{N}{\text{mm}^2}$ ) |
| Hexagonal head screw, prevail torque hex nut |  |   |   |  |
| Class 8.8 - DIN EN 1993-1-8                  | $f_y = 92.82 \text{ ksi}$ (640 $\frac{N}{\text{mm}^2}$ ) | $f_u = 116.03 \text{ ksi}$ (800 $\frac{N}{\text{mm}^2}$ ) | $E = 29000 \text{ ksi}$ (200000 $\frac{N}{\text{mm}^2}$ ) | $G = 11000 \text{ ksi}$ (75845 $\frac{N}{\text{mm}^2}$ ) |

### Instruction For Use:

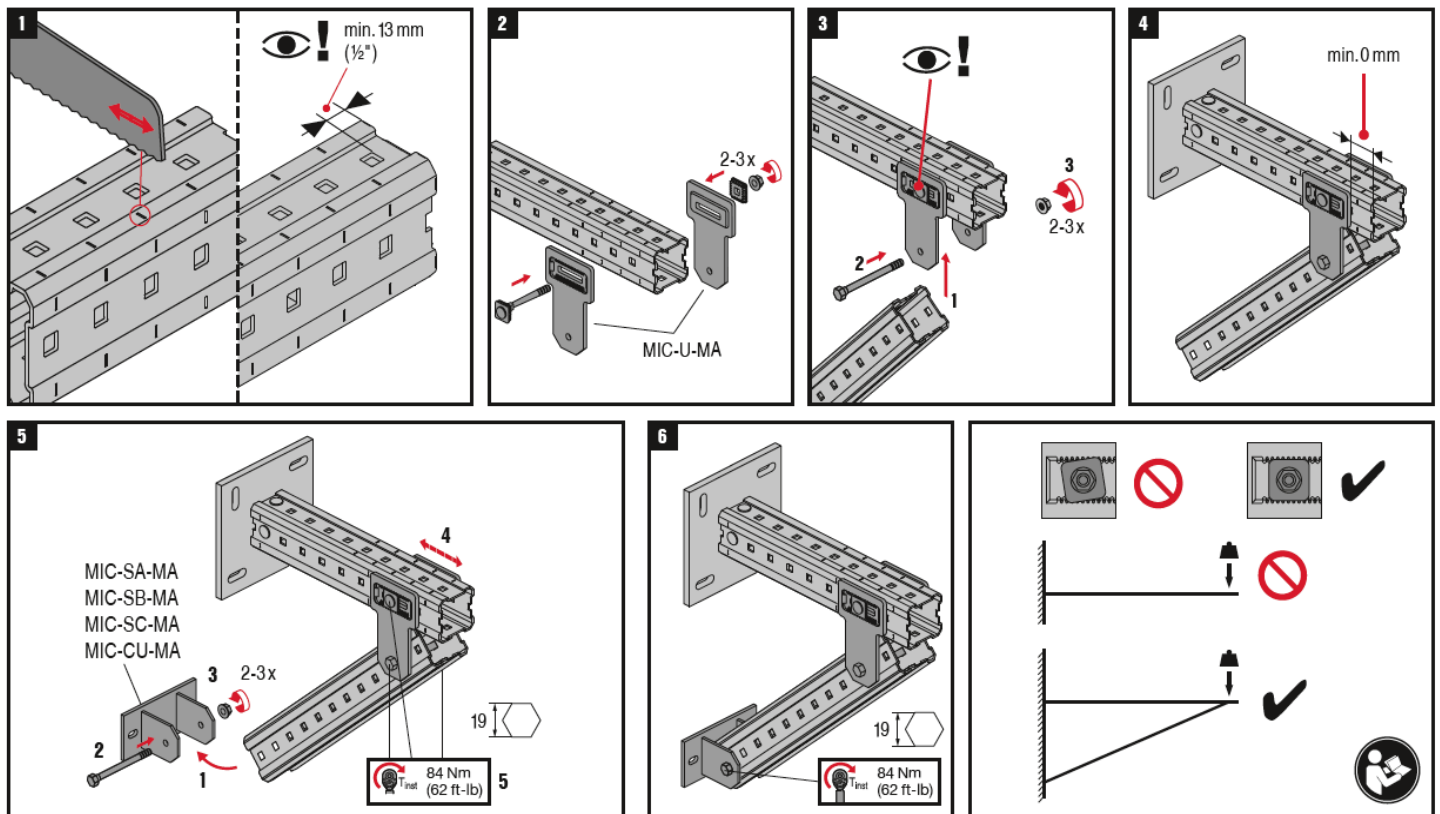

## MIC-SC-MA Base Material Connector - Steel

| Approved loading cases |       |  |
|------------------------|-------|--|
| Clamped                | Boxed |  |
|                        |       |  |

### Governing Conditions

#### Methodology:

Connection strength values are determined with a combination of simulation (ANSYS®), calculation (Microsoft Excel and Mathcad) and testing.

#### Standards and codes:

|                                       |   |         |
|---------------------------------------|---|---------|
| • ANSI/AISC 360-10                    | Specification for Structural Steel Buildings  |         |
| • ANSI/AISC 360-10–<br>Appendix 1     | Inelastic analysis  |         |
| • AISC Steel Design<br>Guide Series 1 | Column Base Plates  |         |
| • AISI S100 - 2007/2010               | North American Specification for the Design of cold<br>formed Steel Structural Members                            |         |
| • ACI 318-08/11                       | Building Code Requirement for Structural Concrete   |         |
| • EN 1993-1-1                         | Eurocode 3: Design of steel structures – Part 1-1:<br>General rules and rules for buildings                       | 03.2012 |
| • EN 1993-1-8                         | Eurocode 3: Design of steel structures – Part 1-8:<br>Design of joints  | 03.2012 |
| • EN 10025-2                          | Hot rolled products of structural steels-Part 2: technical<br>delivery conditions for non-alloy structural steels | 02.2005 |

#### Validity:

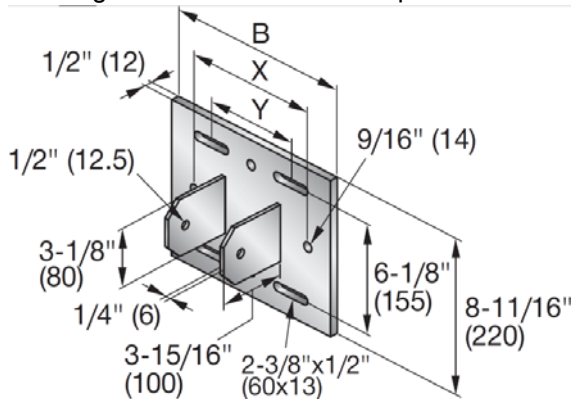

Temperature limits: -22°F (-30°C) to 200°F (+93°C).

Published allowable loads for applications are based on static loading conditions. Non-static forces, including those resulting from thermal or other expansion must be taken into account during design.

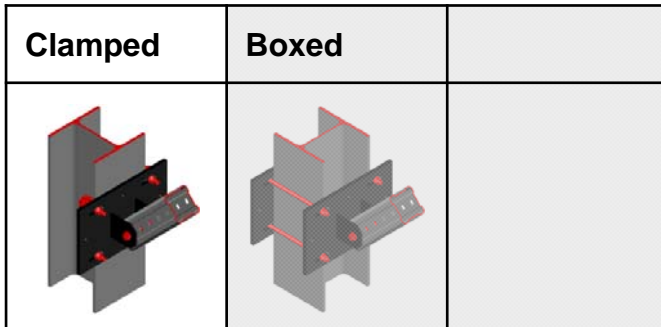

## MIC-SC-MA Base Material Connector - Steel

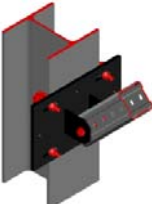

| Loading case: Clamped   | Combinations covered by loading case   |
|---|--|
| <p><b>Bill of Material for this loading case:</b></p> <p><b>MIC-SC-MA</b>                      <b>304817</b><br/>                     Hardware not included in packaging:<br/> <b>Beam clamps</b><br/> <b>4x MI-SGC M12</b>                      <b>233859</b></p>  | <p>Connector used for an angled connection of MI-90 to structural steel profiles (bracing).<br/>                     For flange width 9.25" (235mm) - 11.81" (300mm).</p>  |

### Usage of Values for Design Strength and Allowable Strength

The Design Strength and Allowable Strength tables on the following pages include strength reduction factors:

- ASD:** Safety Factor ( $\omega$ ) > 1.0 as per AISC specifications.
- LRFD:** Strength Reduction Factor ( $\phi$ ) < 1.0 as per AISC specifications.  $\Omega = \frac{1.5}{\phi}$  (Reference AISC 360 C-B3-5)

Factored loads are required for input to the given interaction equations. Factored loads are the responsibility of the user. Factored loads are noted as P, V and M

### Limiting components of capacity evaluated in following tables:

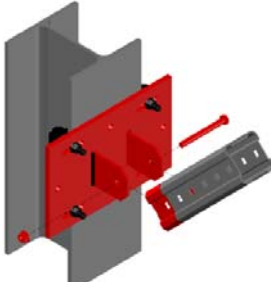
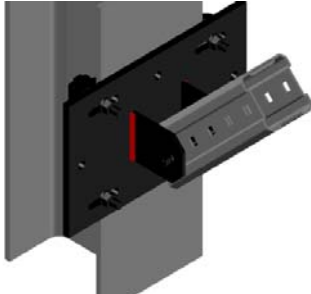
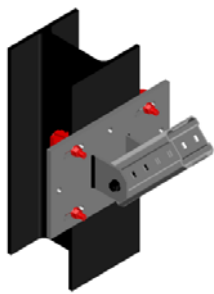
|   |  |  |
|---|--|--|
| 1. Connector steel and all connecting hardware<br> | 2. Welds - per analytical calculation<br> | 3. Beam Clamps - per analytical calculation<br> |
|---|--|--|

## MIC-SC-MA Base Material Connector - Steel

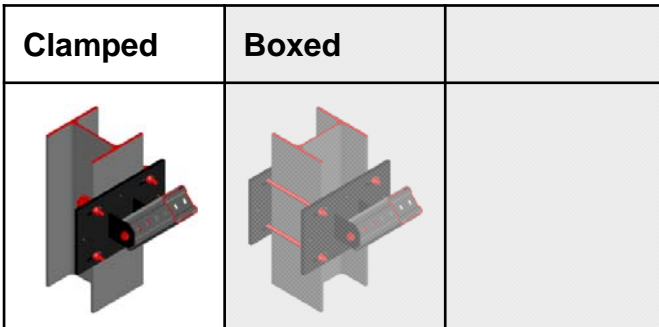

### Values for Design Strength and Allowable Strength

1/3

**NOTE:** Calculate interaction separately for each group only using values from that group. Limiter is defined by highest interaction. Use absolute values. Values refer to the coordinate system shown.

#### 1. Connector steel and all connecting hardware

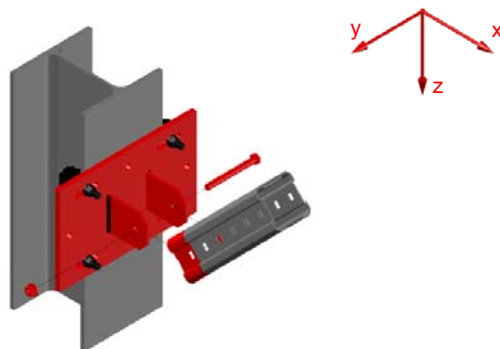

| LRFD* | +Fx      | -Fx      | +Fy      | -Fy      | +Fz      | -Fz      |
|-------|----------|----------|----------|----------|----------|----------|
|       | [kip]    | [kip]    | [kip]    | [kip]    | [kip]    | [kip]    |
|       | 3.75     | 3.75     | 1.48     | 1.48     | 3.75     | 3.75     |
| ASD*  | +Fx      | -Fx      | +Fy      | -Fy      | +Fz      | -Fz      |
|       | [kip]    | [kip]    | [kip]    | [kip]    | [kip]    | [kip]    |
|       | 2.50     | 2.50     | 0.99     | 0.99     | 2.50     | 2.50     |
| LRFD* | +Mx      | -Mx      | +My      | -My      | +Mz      | -Mz      |
|       | [kip*ft] | [kip*ft] | [kip*ft] | [kip*ft] | [kip*ft] | [kip*ft] |
|       | 0.52     | 0.52     | 0.00     | 0.00     | 0.00     | 0.00     |
| ASD*  | +Mx      | -Mx      | +My      | -My      | +Mz      | -Mz      |
|       | [kip*ft] | [kip*ft] | [kip*ft] | [kip*ft] | [kip*ft] | [kip*ft] |
|       | 0.34     | 0.34     | 0.00     | 0.00     | 0.00     | 0.00     |

Note: Design Strength values for girder Torsion about the  $\alpha x$ -axis ( $M_{\alpha x}$ ) are valid for any bracing angle.

Values include verification of hexagonal bolt

#### Interaction for LRFD

Due to the fact, that the same resistance values as for MIC-CU-MA are decisive, the same interaction formulation can be used:

$$\left[ \frac{P_{ux}}{F_x} \right]^2 + \left[ \frac{V_{uz}}{F_z} \right]^2 + \frac{V_{uy}}{F_y} + \frac{M_{ux}}{M_x} \leq 1$$

Use of  $F_{\alpha x}$ : In case only the force along the brace axis ( $\alpha x$ ) is known, determinate load components as follows:

$$P_{ux} = F_{\alpha x} \times \cos(\alpha)$$

$$V_{uz} = F_{\alpha x} \times \sin(\alpha)$$

#### Interaction for ASD:

$$\left[ \frac{P_{ax}}{F_x} \right]^2 + \left[ \frac{V_{az}}{F_z} \right]^2 + \frac{V_{ay}}{F_y} + \frac{M_{ax}}{M_x} \leq 1$$

Use of  $F_a$ : In case only the force along the brace axis ( $\alpha x$ ) is known, determinate load components as follows:

$$P_{ax} = F_{\alpha x} \times \cos(\alpha)$$

$$V_{az} = F_{\alpha x} \times \sin(\alpha)$$

\*Values already include LRFD strength reduction ( $\Phi$ ) or ASD safety ( $\Omega$ ) factors in accordance with AISC, and are based on nominal geometry.



# MIC-SC-MA Base Material Connector - Steel

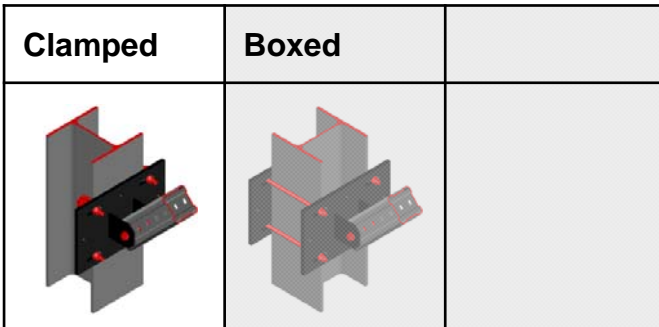

## Values for Design Strength and Allowable Strength

2/3

**NOTE:** Calculate interaction separately for each group only using values from that group. Limiter is defined by highest interaction. Use absolute values. Values refer to the coordinate system shown.

### 2. Welds - per analytical calculation

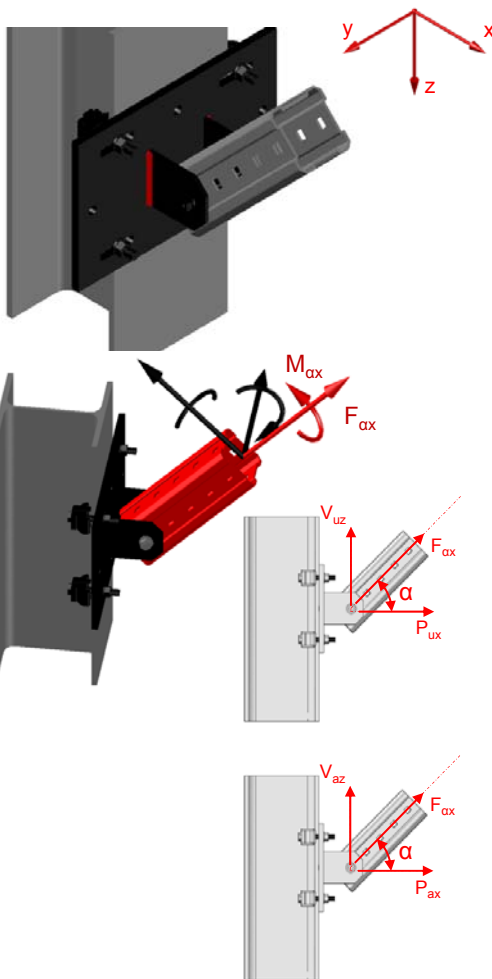

| LRFD* | +Fx      | -Fx      | +Fy      | -Fy      | +Fz      | -Fz      |
|-------|----------|----------|----------|----------|----------|----------|
|       | [kip]    | [kip]    | [kip]    | [kip]    | [kip]    | [kip]    |
|       | 66.29    | 66.29    | 3.02     | 3.02     | 11.74    | 11.74    |
|       | +Mx      | -Mx      | +My      | -My      | +Mz      | -Mz      |
|       | [kip*ft] | [kip*ft] | [kip*ft] | [kip*ft] | [kip*ft] | [kip*ft] |
|       | 1.87     | 1.87     | 0.00     | 0.00     | 0.00     | 0.00     |

| ASD* | +Fx      | -Fx      | +Fy      | -Fy      | +Fz      | -Fz      |
|------|----------|----------|----------|----------|----------|----------|
|      | [kip]    | [kip]    | [kip]    | [kip]    | [kip]    | [kip]    |
|      | 44.19    | 44.19    | 2.01     | 2.01     | 7.83     | 7.83     |
|      | +Mx      | -Mx      | +My      | -My      | +Mz      | -Mz      |
|      | [kip*ft] | [kip*ft] | [kip*ft] | [kip*ft] | [kip*ft] | [kip*ft] |
|      | 1.25     | 1.25     | 0.00     | 0.00     | 0.00     | 0.00     |

#### Interaction for LRFD

Note: Design Strength values for girder Torsion about the x-axis ( $M_{ax}$ ) are valid for any bracing angle.

$$\frac{P_{ux}}{F_x} + \frac{V_{uz}}{F_z} + \frac{V_{uy}}{F_y} + \frac{M_{ux}}{M_x} \leq 1$$

Use of  $F_{ax}$ : In case only the force along the brace axis ( $ax$ ) is known, determinate load components as follows:

$$P_{ux} = F_{ax} \times \cos(\alpha)$$

$$V_{uz} = F_{ax} \times \sin(\alpha)$$

#### Interaction for ASD:

$$\frac{P_{ax}}{F_x} + \frac{V_{az}}{F_z} + \frac{V_{ay}}{F_y} + \frac{M_{ax}}{M_x} \leq 1$$

Use of  $F_{ax}$ : In case only the force along the brace axis ( $ax$ ) is known, determinate load components as follows:

$$P_{ax} = F_{ax} \times \cos(\alpha)$$

$$V_{az} = F_{ax} \times \sin(\alpha)$$

\*Values already include LRFD strength reduction ( $\Phi$ ) or ASD safety ( $\Omega$ ) factors in accordance with AISC, and are based on nominal geometry.

## MIC-SC-MA Base Material Connector - Steel

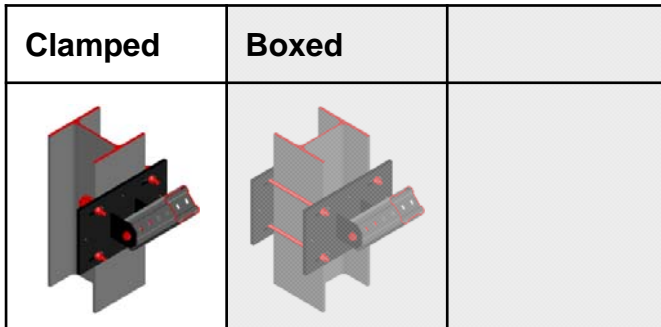

### Values for Design Strength and Allowable Strength

3/3

**NOTE:** Calculate interaction separately for each group only using values from that group. Limiter is defined by highest interaction. Use absolute values. Values refer to the coordinate system shown.

#### 3. Beam Clamps - per analytical calculation

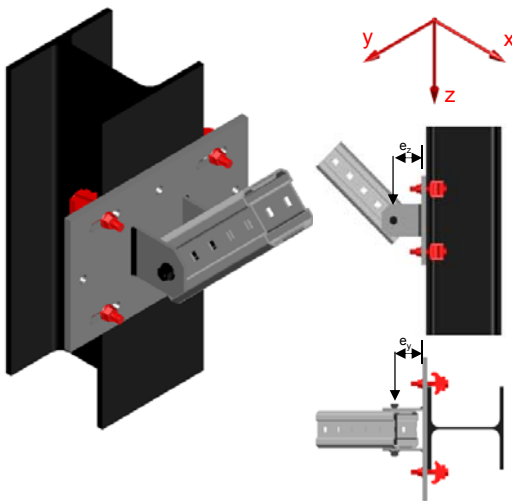

Transition of the forces generated on inclined brace to base material connector's coordinate system

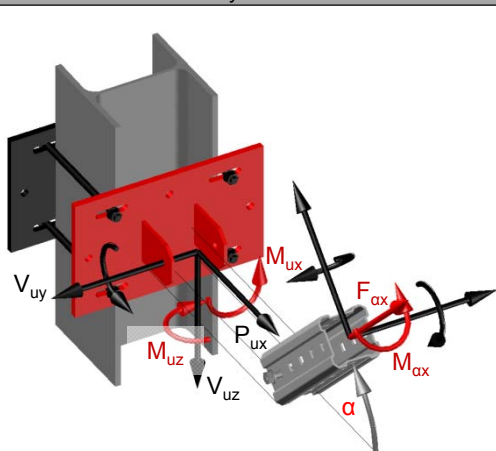

$$M_{ux} = M_{\alpha x} \times \cos(\alpha)$$

$$M_{uz} = M_{\alpha x} \times \sin(\alpha)$$

For ASD (not shown on the picture)

$$M_{\alpha x} = M_{\alpha x} \times \cos(\alpha)$$

$$M_{\alpha z} = M_{\alpha x} \times \sin(\alpha)$$

|       | +Fx<br>[kip]    | -Fx<br>[kip]    | +Fy<br>[kip]    | -Fy<br>[kip]    | +Fz<br>[kip]    | -Fz<br>[kip]    |
|-------|-----------------|-----------------|-----------------|-----------------|-----------------|-----------------|
| LRFD* | 7.04            | Not decisive    | 1.48            | 1.48            | 1.48            | 1.48            |
|       | +Mx<br>[kip*ft] | -Mx<br>[kip*ft] | +My<br>[kip*ft] | -My<br>[kip*ft] | +Mz<br>[kip*ft] | -Mz<br>[kip*ft] |
|       | 0.66            | 0.66            | 1.50            | 1.50            | 1.96            | 1.96            |
|       | +Fx<br>[kip]    | -Fx<br>[kip]    | +Fy<br>[kip]    | -Fy<br>[kip]    | +Fz<br>[kip]    | -Fz<br>[kip]    |
| ASD*  | 4.69            | Not decisive    | 0.99            | 0.99            | 0.99            | 0.99            |
|       | +Mx<br>[kip*ft] | -Mx<br>[kip*ft] | +My<br>[kip*ft] | -My<br>[kip*ft] | +Mz<br>[kip*ft] | -Mz<br>[kip*ft] |
|       | 0.44            | 0.44            | 1.00            | 1.00            | 1.31            | 1.31            |

#### Interaction for LRFD

##### Normal force interaction:

The eccentricity  $e_y$  and  $e_z$  between the point of force transfer channel / connector and baseplate, which generates an bending moment on the system, must be taken into account in the interaction formula.

$$\frac{P_{ux}}{F_x} + \frac{V_{uy} \times ey}{M_z} + \frac{V_{uz} \times ez}{M_y} + \frac{M_{uz}}{M_z} \leq 1$$

with  $e_y=e_z=0.070$  m

##### Shear force interaction:

- Shear Interaction Equation is only valid for TENSILE  $P_{ux}$  loads ( $P_{ux} > 0$ ). Equation is not valid for compressive  $P_{ux}$  loads ( $P_{ux} < 0$ ).

- For Shear interaction, user must ADDITIONALLY verify:  $P_{ux} / F_x < 1$ .

$$\sqrt{\left(\frac{V_{uy}}{F_y \times \left(1 - \frac{P_{ux}}{F_x}\right)}\right)^2 + \left(\frac{V_{uz}}{F_z \times \left(1 - \frac{P_{ux}}{F_x}\right)}\right)^2} + \frac{M_{ux}}{M_x \times \left(1 - \frac{P_{ux}}{F_x}\right)} \leq 1$$

Note: Due to the fact, that depending on the inclination of the channel, the acting torsional moment  $M_{\alpha x}$  can either generate shear or tension, it will be considered in both interactions.

#### Interaction for ASD:

##### Normal force interaction:

The eccentricity  $e_y$  and  $e_z$  between the point of force transfer channel / connector and baseplate, which generates an additional bending moment on the system, must be taken into account in the interaction formula.

$$\frac{P_{ax}}{F_x} + \frac{V_{ay} \times ey}{M_z} + \frac{V_{az} \times ez}{M_y} + \frac{M_{az}}{M_z} \leq 1$$

with  $e_y=e_z=0.070$  m

##### Shear force interaction:

- Shear Interaction Equation is only valid for TENSILE  $P_{ax}$  loads ( $P_{ax} > 0$ ). Equation is not valid for compressive  $P_{ax}$  loads ( $P_{ax} < 0$ ).

- For Shear interaction, user must ADDITIONALLY verify:  $P_{ax} / F_x < 1$ .

$$\sqrt{\left(\frac{V_{ay}}{F_y \times \left(1 - \frac{P_{ax}}{F_x}\right)}\right)^2 + \left(\frac{V_{az}}{F_z \times \left(1 - \frac{P_{ax}}{F_x}\right)}\right)^2} + \frac{M_{ax}}{M_x \times \left(1 - \frac{P_{ax}}{F_x}\right)} \leq 1$$

\*Values already include LRFD strength reduction ( $\Phi$ ) or ASD safety ( $\Omega$ ) factors in accordance with AISC, and are based on nominal geometry.



## MIC-SC-MA Base Material Connector - Steel

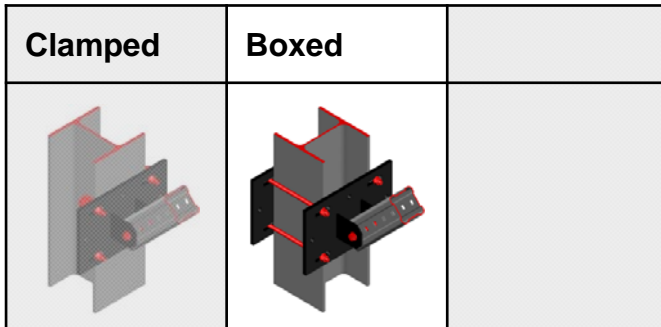

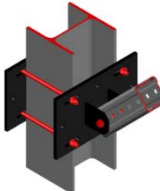
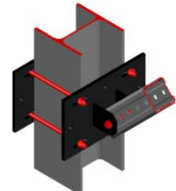
| Loading case: Boxed   | Combinations covered by loading case  |
|---|---|
| <p><b>Bill of Material for this loading case:</b></p> <p>1x MIC-SC-MA                      304817</p> <p>Hardware not included in packaging:</p> <p><b>Base plate</b></p> <p>1x MIB-SC                              304823</p> <p><b>Threaded rods cut to particular length</b></p> <p>4x AM12x1000 8.8 HDG...m   419103</p> <p><b>Nut</b></p> <p>8x M12-F-SL WS3/4                382897</p>  | <p>Connector used for an angled connection of MI-90 to structural steel profiles (bracing).</p> <p>For flange width 9.25" (235mm) - 11.81" (300mm).</p>  |

### Usage of Values for Design Strength and Allowable Strength

The Design Strength and Allowable Strength tables on the following pages include strength reduction factors:

- ASD:** Safety Factor (omega) > 1.0 as per AISC specifications.
- LRFD:** Strength Reduction Factor (phi) < 1.0 as per AISC specifications.  $\Omega = \frac{1.5}{\phi}$  (Reference AISC 360 C-B3-5)

Factored loads are required for input to the given interaction equations. Factored loads are the responsibility of the user. Factored loads are noted as P, V and M

### Limiting components of capacity evaluated in following tables:

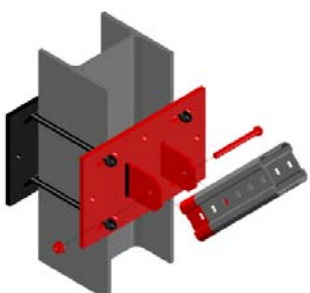
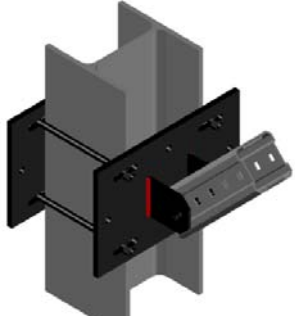
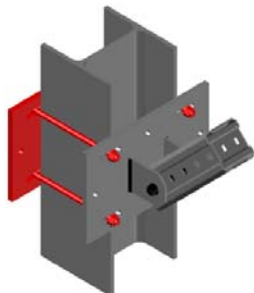
|   |  |   |
|---|--|---|
| <p>1. Connector steel and all connecting hardware</p>  | <p>2. Welds - per analytical calculation</p>  | <p>3. Base plate and through bolts - per analytical calculation</p>  |
|---|--|---|

## MIC-SC-MA Base Material Connector - Steel

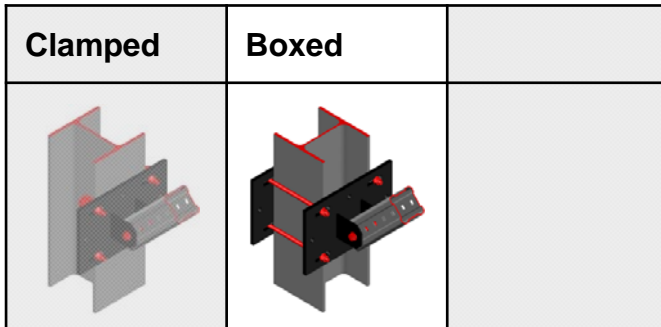

### Values for Design Strength and Allowable Strength

1/3

**NOTE:** Calculate interaction separately for each group only using values from that group. Limiter is defined by highest interaction. Use absolute values. Values refer to the coordinate system shown.

#### 1. Connector steel and all connecting hardware

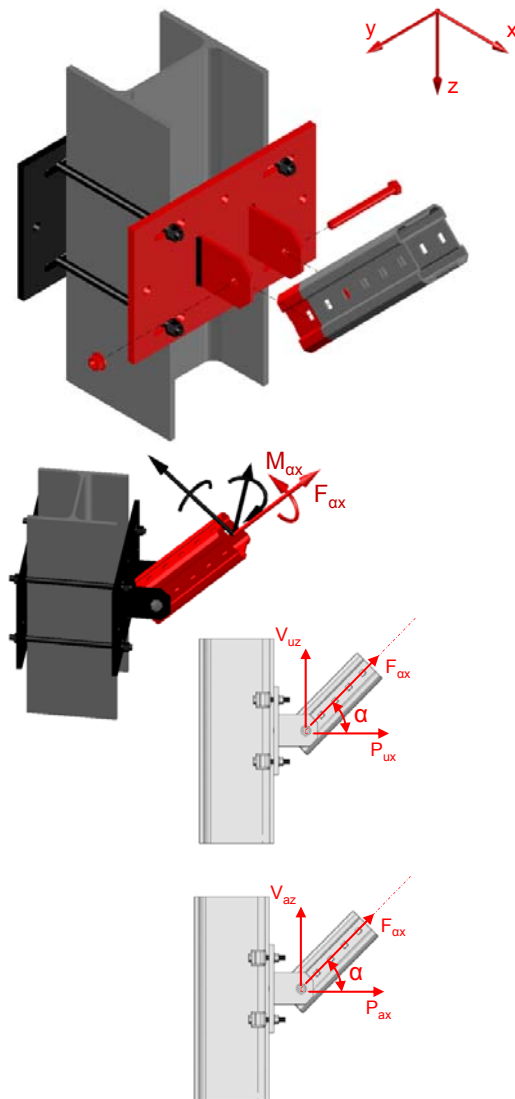

| LRFD* | +Fx      | -Fx      | +Fy      | -Fy      | +Fz      | -Fz      |
|-------|----------|----------|----------|----------|----------|----------|
|       | [kip]    | [kip]    | [kip]    | [kip]    | [kip]    | [kip]    |
|       | 3.75     | 3.75     | 1.48     | 1.48     | 3.75     | 3.75     |
| ASD*  | +Mx      | -Mx      | +My      | -My      | +Mz      | -Mz      |
|       | [kip*ft] | [kip*ft] | [kip*ft] | [kip*ft] | [kip*ft] | [kip*ft] |
|       | 0.52     | 0.52     | 0.00     | 0.00     | 0.00     | 0.00     |

| LRFD* | +Fx      | -Fx      | +Fy      | -Fy      | +Fz      | -Fz      |
|-------|----------|----------|----------|----------|----------|----------|
|       | [kip]    | [kip]    | [kip]    | [kip]    | [kip]    | [kip]    |
|       | 2.50     | 2.50     | 0.99     | 0.99     | 2.50     | 2.50     |
| ASD*  | +Mx      | -Mx      | +My      | -My      | +Mz      | -Mz      |
|       | [kip*ft] | [kip*ft] | [kip*ft] | [kip*ft] | [kip*ft] | [kip*ft] |
|       | 0.34     | 0.34     | 0.00     | 0.00     | 0.00     | 0.00     |

Note: Design Strength values for girder Torsion about the x-axis ( $M_{ax}$ ) are valid for any bracing angle. Values include verification of hexagonal bolt

#### Interaction for LRFD

Due to the fact, that the same resistance values as for MIC-CU-MA are decisive, the same interaction formulation can be used:

$$\left[ \frac{P_{ux}}{F_x} \right]^2 + \left[ \frac{V_{uz}}{F_z} \right]^2 + \frac{V_{uy}}{F_y} + \frac{M_{ux}}{M_x} \leq 1$$

Use of  $F_{ax}$ : In case only the force along the brace axis ( $ax$ ) is known, determinate load components as follows:

$$P_{ux} = F_{ax} \times \cos(\alpha)$$

$$V_{uz} = F_{ax} \times \sin(\alpha)$$

#### Interaction for ASD:

$$\left[ \frac{P_{ax}}{F_x} \right]^2 + \left[ \frac{V_{az}}{F_z} \right]^2 + \frac{V_{ay}}{F_y} + \frac{M_{ax}}{M_x} \leq 1$$

Use of  $F_{ax}$ : In case only the force along the brace axis ( $ax$ ) is known, determinate load components as follows:

$$P_{ax} = F_{ax} \times \cos(\alpha)$$

$$V_{az} = F_{ax} \times \sin(\alpha)$$

\*Values already include LRFD strength reduction ( $\Phi$ ) or ASD safety ( $\Omega$ ) factors in accordance with AISC, and are based on nominal geometry.

## MIC-SC-MA Base Material Connector - Steel

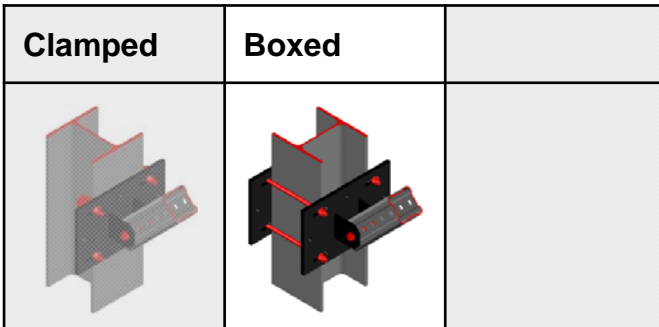

### Values for Design Strength and Allowable Strength

2/3

**NOTE:** Calculate interaction separately for each group only using values from that group. Limiter is defined by highest interaction. Use absolute values. Values refer to the coordinate system shown.

#### 2. Welds - per analytical calculation

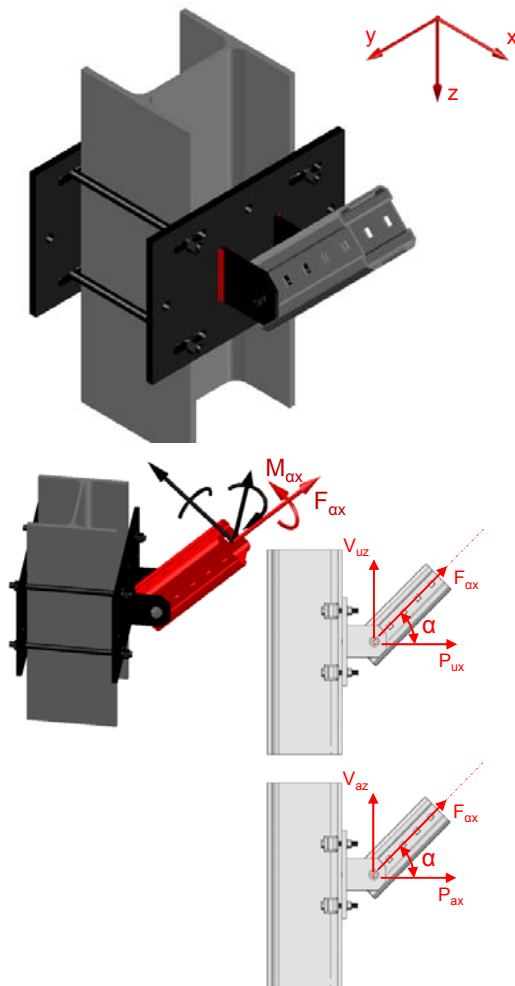

| LRFD* | +Fx      | -Fx      | +Fy      | -Fy      | +Fz      | -Fz      |
|-------|----------|----------|----------|----------|----------|----------|
|       | [kip]    | [kip]    | [kip]    | [kip]    | [kip]    | [kip]    |
|       | 66.29    | 66.29    | 3.02     | 3.02     | 11.74    | 11.74    |
| ASD*  | +Fx      | -Fx      | +Fy      | -Fy      | +Fz      | -Fz      |
|       | [kip]    | [kip]    | [kip]    | [kip]    | [kip]    | [kip]    |
|       | 44.19    | 44.19    | 2.01     | 2.01     | 7.83     | 7.83     |
| LRFD* | +Mx      | -Mx      | +My      | -My      | +Mz      | -Mz      |
|       | [kip*ft] | [kip*ft] | [kip*ft] | [kip*ft] | [kip*ft] | [kip*ft] |
|       | 1.87     | 1.87     | 0.00     | 0.00     | 0.00     | 0.00     |
| ASD*  | +Mx      | -Mx      | +My      | -My      | +Mz      | -Mz      |
|       | [kip*ft] | [kip*ft] | [kip*ft] | [kip*ft] | [kip*ft] | [kip*ft] |
|       | 1.25     | 1.25     | 0.00     | 0.00     | 0.00     | 0.00     |

#### Interaction for LRFD

Note: Design Strength values for girder Torsion about the x-axis ( $M_{ax}$ ) are valid for any bracing angle.

$$\frac{P_{ux}}{F_x} + \frac{V_{uz}}{F_z} + \frac{V_{uy}}{F_y} + \frac{M_{ux}}{M_x} \leq 1$$

Use of  $F_{ax}$ : In case only the force along the brace axis ( $\alpha$ ) is known, determinate load components as follows:

$$P_{ux} = F_{ax} \times \cos(\alpha)$$

$$V_{uz} = F_{ax} \times \sin(\alpha)$$

#### Interaction for ASD:

$$\frac{P_{ax}}{F_x} + \frac{V_{az}}{F_z} + \frac{V_{ay}}{F_y} + \frac{M_{ax}}{M_x} \leq 1$$

Use of  $F_{ax}$ : In case only the force along the brace axis ( $\alpha$ ) is known, determinate load components as follows:

$$P_{ax} = F_{ax} \times \cos(\alpha)$$

$$V_{az} = F_{ax} \times \sin(\alpha)$$

\*Values already include LRFD strength reduction ( $\Phi$ ) or ASD safety ( $\Omega$ ) factors in accordance with AISC, and are based on nominal geometry.

## MIC-SC-MA Base Material Connector - Steel

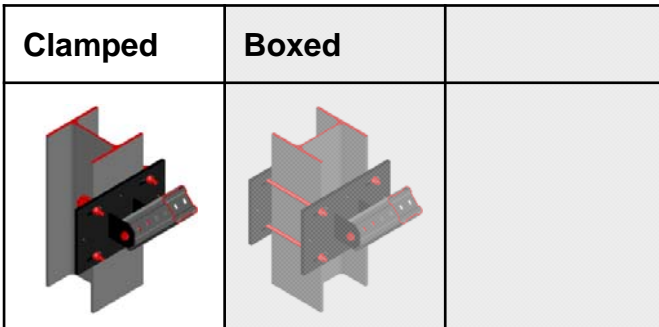

### Values for Design Strength and Allowable Strength

3/3

**NOTE:** Calculate interaction separately for each group only using values from that group. Limiter is defined by highest interaction. Use absolute values. Values refer to the coordinate system shown.

#### 3. Beam Clamps - per analytical calculation

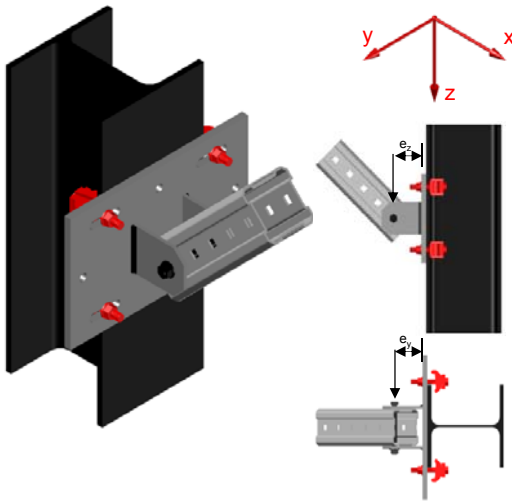

Transition of the forces generated on inclined brace to base material connector's coordinate system

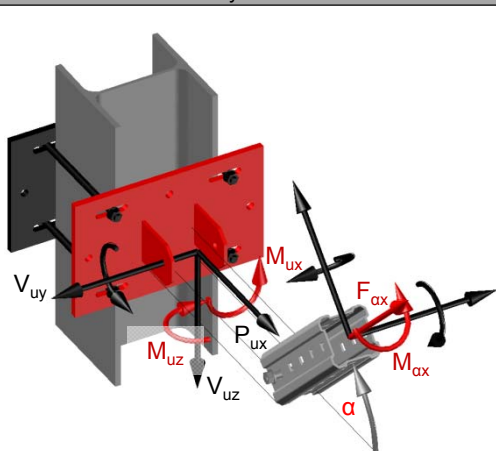

$$M_{ux} = M_{ox} \times \cos(\alpha)$$

$$M_{uz} = M_{ox} \times \sin(\alpha)$$

For ASD (not shown on the picture)

$$M_{ax} = M_{ox} \times \cos(\alpha)$$

$$M_{az} = M_{ox} \times \sin(\alpha)$$

|       | +Fx<br>[kip]    | -Fx<br>[kip]    | +Fy<br>[kip]    | -Fy<br>[kip]    | +Fz<br>[kip]    | -Fz<br>[kip]    |
|-------|-----------------|-----------------|-----------------|-----------------|-----------------|-----------------|
| LRFD* | 9.85            | Not<br>decisive | 2.07            | 2.07            | 2.07            | 2.07            |
|       | +Mx<br>[kip*ft] | -Mx<br>[kip*ft] | +My<br>[kip*ft] | -My<br>[kip*ft] | +Mz<br>[kip*ft] | -Mz<br>[kip*ft] |
|       | 0.90            | 0.90            | 1.94            | 1.94            | 2.74            | 2.74            |
|       | +Fx<br>[kip]    | -Fx<br>[kip]    | +Fy<br>[kip]    | -Fy<br>[kip]    | +Fz<br>[kip]    | -Fz<br>[kip]    |
| ASD*  | 6.56            | Not<br>decisive | 1.38            | 1.38            | 1.38            | 1.38            |
|       | +Mx<br>[kip*ft] | -Mx<br>[kip*ft] | +My<br>[kip*ft] | -My<br>[kip*ft] | +Mz<br>[kip*ft] | -Mz<br>[kip*ft] |
|       | 0.60            | 0.60            | 1.29            | 1.29            | 1.83            | 1.83            |

#### Interaction for LRFD

##### Normal force interaction:

The eccentricity  $e_y$  and  $e_z$  between the point of force transfer channel / connector and baseplate, which generates an additional bending moment on the system, must be taken into account in the interaction formula.

$$\frac{P_{ux}}{F_x} + \frac{V_{uy} \times e_y}{M_z} + \frac{V_{uz} \times e_z}{M_y} + \frac{M_{uz}}{M_z} \leq 1$$

with  $e_y=e_z=0.070$  m

##### Shear force interaction:

- Shear Interaction Equation is only valid for TENSILE  $P_{ux}$  loads ( $P_{ux} > 0$ ). Equation is not valid for compressive  $P_{ux}$  loads ( $P_{ux} < 0$ ).

- For Shear interaction, user must ADDITIONALLY verify:  $P_{ux} / F_x < 1$ .

$$\sqrt{\left(\frac{V_{uy}}{F_y \times \left(1 - \frac{P_{ux}}{F_x}\right)}\right)^2 + \left(\frac{V_{uz}}{F_z \times \left(1 - \frac{P_{ux}}{F_x}\right)}\right)^2} + \frac{M_{ux}}{M_x \times \left(1 - \frac{P_{ux}}{F_x}\right)} \leq 1$$

Note: Due to the fact, that depending on the inclination of the channel, the acting torsional moment  $M_{ax}$  can either generate shear or tension it will be considered in both interactions.

#### Interaction for ASD:

##### Normal force interaction:

The eccentricity  $e_y$  and  $e_z$  between the point of force transfer channel / connector and baseplate, which generates an additional bending moment on the system, must be taken into account in the interaction formula.

$$\frac{P_{ax}}{F_x} + \frac{V_{ay} \times e_y}{M_z} + \frac{V_{az} \times e_z}{M_y} + \frac{M_{az}}{M_z} \leq 1$$

with  $e_y=e_z=0.070$  m

##### Shear force interaction:

- Shear Interaction Equation is only valid for TENSILE  $P_{ax}$  loads ( $P_{ax} > 0$ ). Equation is not valid for compressive  $P_{ax}$  loads ( $P_{ax} < 0$ ).

- For Shear interaction, user must ADDITIONALLY verify:  $P_{ax} / F_x < 1$ .

$$\sqrt{\left(\frac{V_{ay}}{F_y \times \left(1 - \frac{P_{ax}}{F_x}\right)}\right)^2 + \left(\frac{V_{az}}{F_z \times \left(1 - \frac{P_{ax}}{F_x}\right)}\right)^2} + \frac{M_{ax}}{M_x \times \left(1 - \frac{P_{ax}}{F_x}\right)} \leq 1$$

\*Values already include LRFD strength reduction ( $\Phi$ ) or ASD safety ( $\Omega$ ) factors in accordance with AISC, and are based on nominal geometry.





**In the US:**

Hilti, Inc. (U.S.)  
P.O. Box 21148 Tulsa, OK 74121  
Customer Service: 1-800-879-8000  
en español: 1-800-879-5000  
Fax: 1-800-879-7000

[www.us.hilti.com](http://www.us.hilti.com)

Hilti is an equal opportunity employer  
Hilti is a registered trademark of Hilti, Corp.  
©Copyright 2017 by Hilti, Inc. (U.S.)

**In Canada:**

Hilti (Canada) Corporation  
2360 Meadowpine Blvd.  
Mississauga, Ontario, L5N 6S2  
Customer Service: 1-800-363-4458  
Fax: 1-800-363-4459

[www.hilti.ca](http://www.hilti.ca)

The data contained in this literature was current as of the date of publication. Updates and changes may be made based on later testing. If verification is needed that the data is still current, please contact the Hilti Technical Support Specialists at 1-800-879-8000 (U.S.) or 1-800-363-4458 (Canada). All published load values contained in this literature represent the result of testing by Hilti or test organizations. Local base materials were used. Because of variations in materials, on-site testing is necessary to determinate performance at any specific site.