



APPLICATION:

**Joints Between Curtain Wall**

ID:

**SP-WB:LJ-CW**

**INFORMATION:**

- Not to scale
- All units are in millimetres
- Tested according EN 1364-4
- [Approval ETA-11/0343](#)

**CFS-SP WB Joint Spray**

REV:

**01**

DATE:

**10/2024**

**Fire Rating up to EI 180**

**Page 3/3**

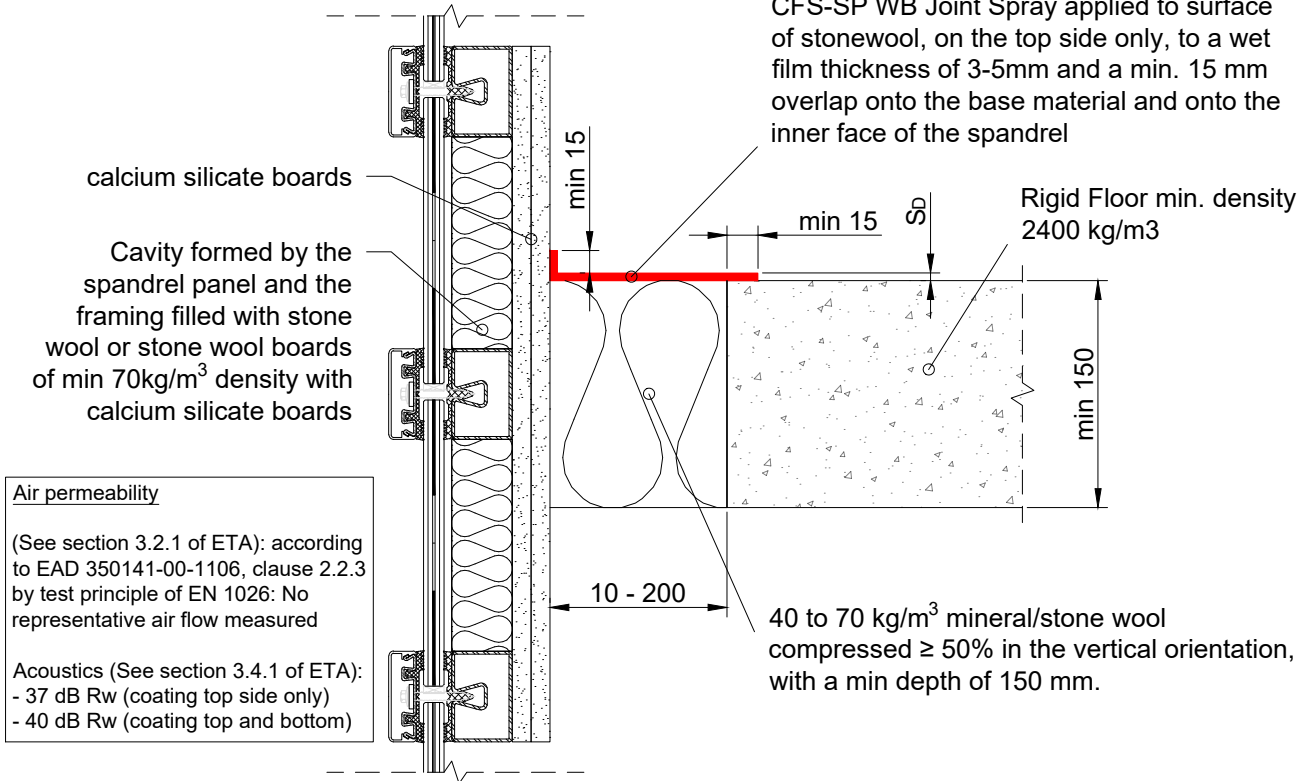

Curtain Wall Type	Joint Width	S <sub>D</sub> Sealant Depth	Mineral Backfilling Compression (%)	Classification
Aluminium Framed	10 - 200	min. 3-5 wet film thickness to achieve 2 dry film thickness	≥ 50 <sup>1</sup>	EI 180-H-F-M25-W 10 to W 200
Steel Framed	10 - 200	min. 3-5 wet film thickness to achieve 2 dry film thickness	≥ 50 <sup>1</sup>	EI 90-H-F-M25-W 10 to W 200

<sup>1</sup>Mineral wool must be pressed into the joint taking into consideration, that the uncompressed thickness of the mineral wool board before installation must be at least 20mm (for 10mm joint) and up to 200 mm (for a 100mm joint).

Horizontal Distant	Vertical Deflection	Horizontal Deflection
25	16.67	6.25
50	33.33	12.50
75	50.00	18.75
100	66.67	25.00
125	83.33	31.25
150	100.00	37.55
175	116.67	43.75
200	133.33	50.00

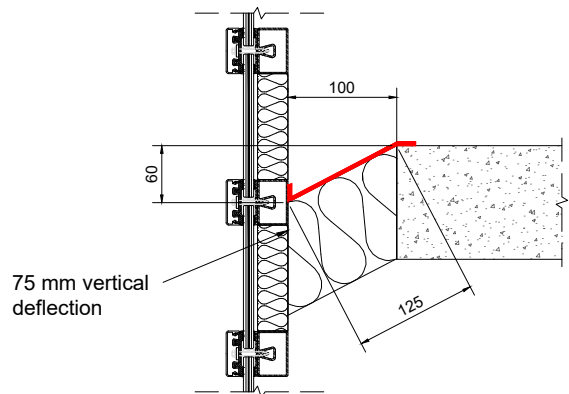

Maximum Movement Capability: ± 25 % horizontal and vertical movement, see above table for min. joint width recommendations to suit specific movement requirements. Please note, these are different and not to be combined. For combined movement, please contact Hilti for further support.

1. The application limits on this detail are for guidance purposes only. For more detailed information based on the full range of available test results please contact the Hilti Technical Advisory Service.  
 2. The product and application has been assessed as a minimum to the BS 476 standard. It may have additional European and worldwide testing. Please contact Hilti for further information.  
 3. All installations should be carried out in accordance with Hilti's installation instructions and by competent & experienced installers using Hilti branded products.  
 4. All services are to be correctly and adequately supported to prevent collapse and distortion.